

HUMIDITY SENSOR ZS-12

Exhaust air moisture up – Energy down!

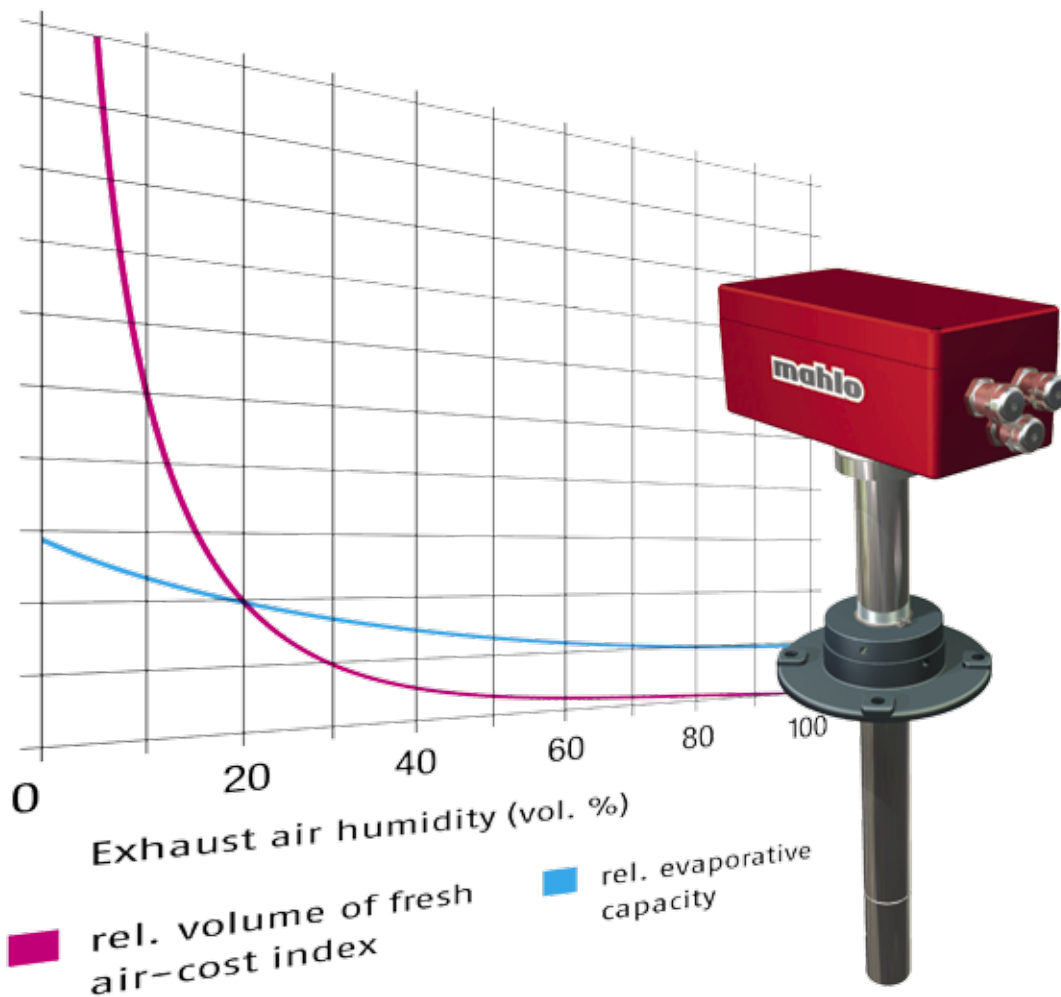

HUMIDITY SENSOR ZS-12

EXHAUST AIR MOISTURE CONTROL



TEXTILE



NONWOVEN



COATING &
CONVERTING



PAPER



EXTRUSION

HUMIDITY SENSOR ZS-12

EXHAUST AIR MOISTURE UP – ENERGY DOWN!



Much unused energy is wasted through the exhaust air during drying processes without appropriate control. The humidity sensor ZS-12 adapts the heating energy to the actual demand by monitoring the vapour content of the exhaust air and then controls this factor through the fan speed or the exhaust air vent control.

- The energy demand is reduced by the controlled heating demand.
- The constant conditions produced by the control increase the reproducibility of the production process and the product quality.

Product-highlights

- ✓ Non-contact measurement of product temperature
- ✓ High-temperature proof sensors
- ✓ Low maintenance requirements
- ✓ Easy to install
- ✓ Self-cleaning sensors

Customer benefits

- ✓ Maximum repeatability
- ✓ Optimal utilisation of stenter capacity
- ✓ Low energy consumption per meter of product
- ✓ Ultra-reliable processing
- ✓ Short payback times
- ✓ Elimination of safety margins

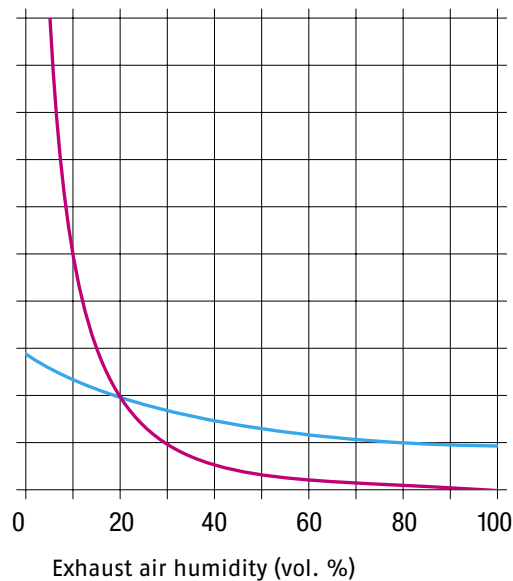

■ rel. volume of fresh air-cost index ■ rel. evaporative capacity

Maximising the exhaust air moisture from 8 to 15 vol. % results in

- reduction of energy consumption by 23 %
- reduction of production costs by 6 %
- maintaining a consistent production speed.

Prerequisite: Working time 240 days/at 3 shifts; product weight: 150 g/m²; product width: 1.6 m; initial moisture: 75 %; residual moisture: 4 %; product speed: 100 m/min; fresh air: 25 °C; exhaust air: 160 °C

Sensor	Humidity Sensor ZS-12			
Measuring range	H ₂ O 30/50/100 Vol. %; 266/622/1000 g/kg;			
Accuracy	≤ 2 Vol. % of maximum scale reading			
Sensor ports	0-20 mA, 4-20 mA			
Max. working temperature	Sensor controller:	0...+65 °C	Sensor:	0...+ 250 °C
Power supply	24 V DC, 0,5 A; 24 V AC, 0,7 A			
Connection	3 EMC cable glands M16 x 1,5, with shield clamping range, protection class IP 67			
Sound pressure level	< 70 dB (A)			
Mechanical data	Sensor	Sensor controller		
Construction	Stainless-steel stem	Die-cast aluminium casing		
Proofing standards	Against measured gases only!	IP 67		
Weight	28 N (~ 2,8 kg)			

Dimensions

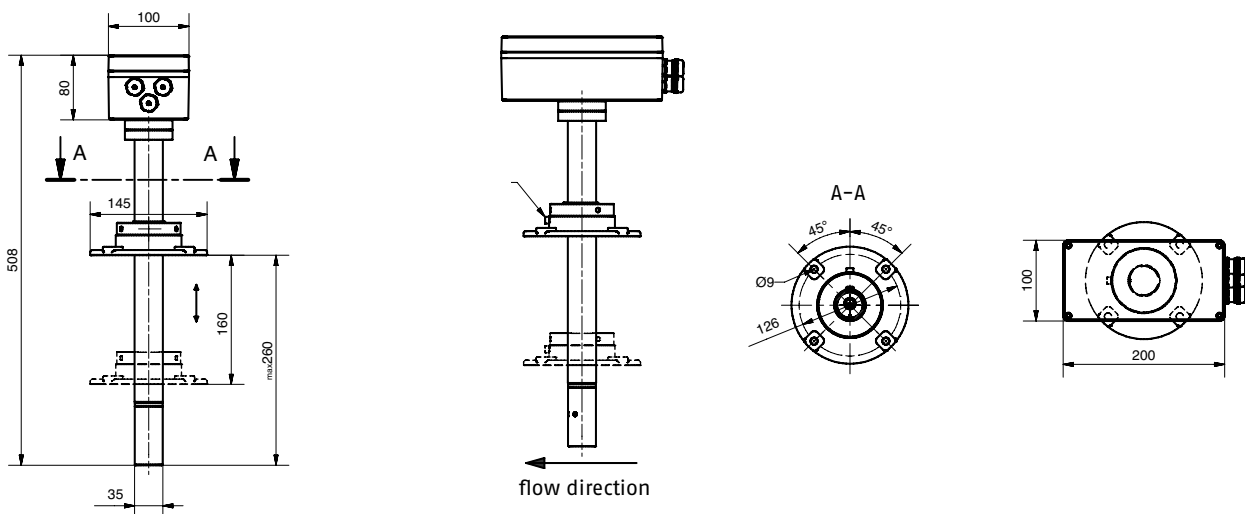

Humidity Sensor ZS-12
91-015470-01

Monitoring and control systems, automation:

MAHLO® GUARANTEES QUALITY. WORLDWIDE, IN YOUR VICINITY.

Best-possible technical support and transfer of know-how are written in capital letters at Mahlo®. Thanks to an international network of agencies and service centres, customers have at their disposal competent support worldwide. We are there for you 365 days a year, 24 hours a day. Just get in touch with us!

- ✓ Over 40 service centres worldwide
- ✓ Prompt service and supply of spare parts within 24 hours
- ✓ Remote diagnostic system
- ✓ Service-hotline: +49-180-5062456



Mahlo GmbH + Co. KG Germany

Donaustr. 12, 93342 Saal/Donau
Tel.: +49-9441-601-0
Fax: +49-9441-601-102
info@mahlo.com

Mahlo Italia S.R.L. Italy

Via Fiume 62, 21020 Daverio
Tel.: +39-0332-94-95-58
Fax: +39-0332-94-85-86
mahlo.italia@mahlo.com

Mahlo America Inc. USA

P.O. Box 2825, Spartanburg, S.C. 29304
Tel.: +1-864-576-62-88
Fax: +1-864-576-00-09
mahlo.america@mahlo.com

Mahlo España S.L. Spain

C/ Santa Margarida, s/n - Nave nº13
Polígono Industrial Riera de Caldes - Boada Vell
Eo8184 Palau Solità i Plegamans (Barcelona)
Tel.: +34-938-640-549
mahlo.espana@mahlo.com

Mahlo Ouest S.P.R.L. Belgium

Quartum Center
Hütte 79 - Bte 10
4700 Eupen
Tel.: +32-87-59-69-00
Fax: +32-87-59-69-09
mahlo.ouest@mahlo.com

Mahlo do Brasil Ltda. Brazil

Rua dos Lírios 849 e 851
Cidade Jardim II - Americana - SP
Brasil CEP- 13466-580
Tel.: +55-19-3407-7954 / +55-19-3601-7363
Fax: +55-19-3405-4743
mahlo.brazil@mahlo.com

WWW.MAHLO.COM

HUMIDITY SENSOR ZS-12 84-010021-004-en
Subject to revision! © Mahlo GmbH + Co. KG



Quality made
in Germany